

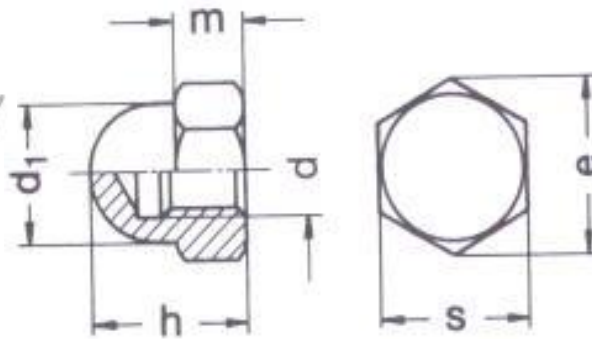

DIN1587



All measurements in millimeters (mm)

d	h	m max	d1 max	s	e
M3	7	2.4	5.5	5.5	6.01
M4	8	3.2	6.5	7	7.66
M5	10	4	7.5	8	8.79
M6	12	5	9.5	10	11.05
M8	15	6.5	12.5	13	14.38
M10	18	8	16	17	18.9
M12	22	10	18	19	21.1
M14	25	11	21	22	24.49
M16	28	13	23	24	26.75
M20	34	16	28	30	33.53
M24	42	19	34	36	39.98



2301, Tian Ning Building, 138 West Zhong Shan Road, Ningbo City, 315010 China

Tel: +86-574-8736-7873 Fax: +86-574-8736-4349 E-mail: transhow@transhow.com.cn

Copyright © 2006 Transshow industry Limited. All Right Reserved